

Nanodyne Replacement Illuminator for Olympus BX50 & BX51 Top Illuminator Installation Instructions

Refer to the photos below to determine which type of illuminator is required, or that you have the correct items if already purchased. The basic Nanodyne illuminator is the same for both, but there are different options for intensity control.



Top Illuminator for viewing the sample by reflected light off the surface.

For this configuration, the intensity control pot is normally located on the side of the Nanodyne illuminator, and the installation does not require opening the microscope itself. The original controls are left in place, but no longer used. (BX50 shown, also for BX51)

Follow the instructions in this document to install the Nanodyne replacement for the top illuminator.

If desired, the same intensity control as used for the lower illuminator may be requested. This does make the installation a bit more involved. See the instructions for the lower illuminator configuration.



Bottom illuminator for viewing by light transmitted through the sample.

If you are replacing this illuminator, you need PN 10408 Olympus BX50 (or PN 10413 Olympus BX51) Illuminator System (bottom illuminator). Please refer to installation document PN 10408 Olympus BX50 (or PN 10413 Olympus BX51) Bottom Illuminator Installation Instructions.

Important Note: This illuminator is intended to replace halogen (white light) illuminators. It is NOT intended as a replacement for mercury vapor (UV) lamps used for fluorescence.

Wayne Bonin 10/24/2019

PN 10401 Olympus BX50-51 Top Illuminator Installation Instructions REV 7

SHEET 1 OF 4

Nanodyne Replacement Illuminator for Olympus BX50 & BX51 Top Illuminator Installation Instructions: Included Items

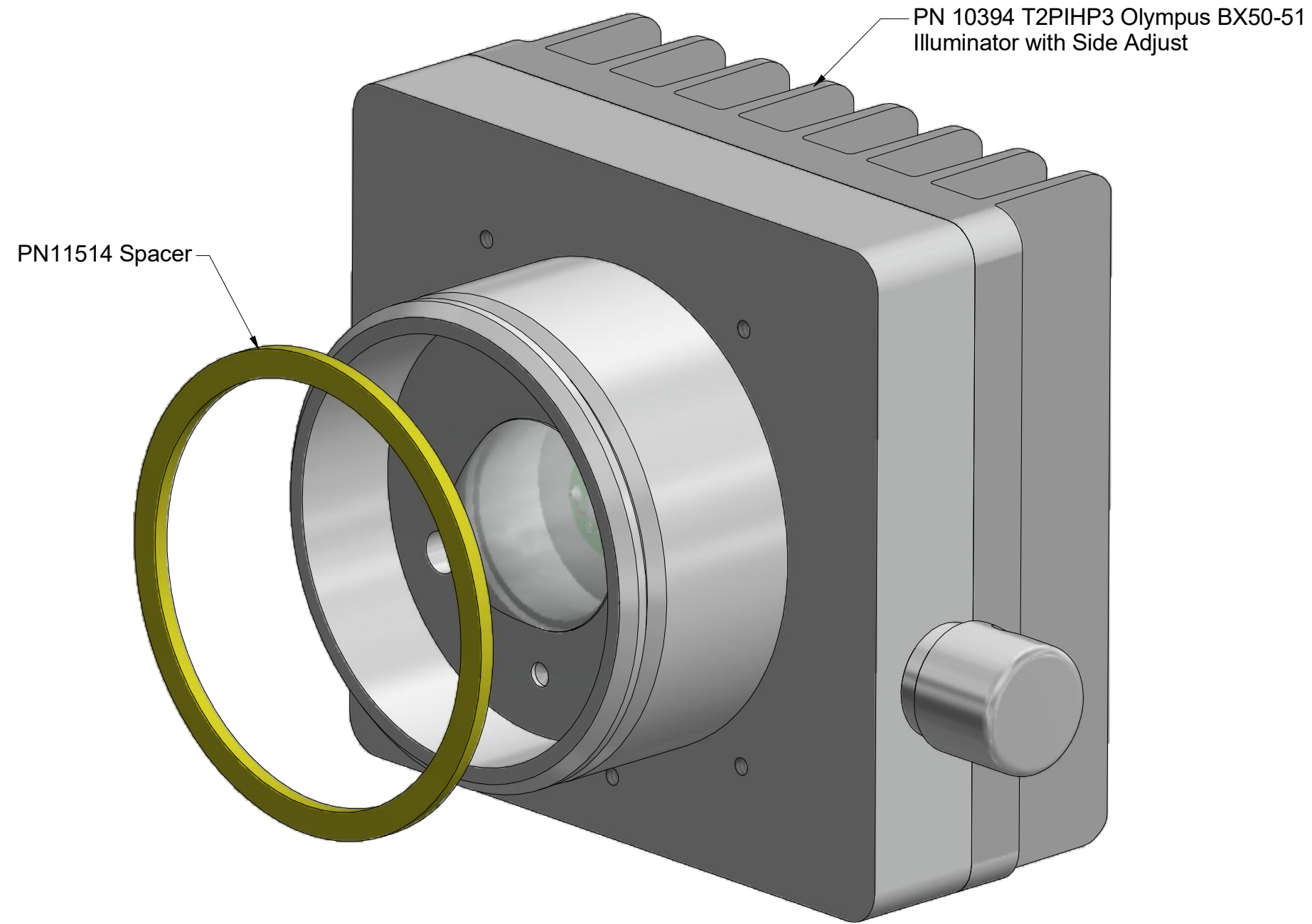

Power supplies are subject to change due to availability and regulations.

The illuminator may be powered by plugging the cable into the power supply provided, or into a suitable USB port on a computer or other device.



PN 11163 Power Supply 5V 2.1A and PN 10734 Power Cable 1.35mm ID/3.5mm OD x USB A 6 ft.



PN 10736 Rubber plug to block unused AC power recepticle.

Wayne Bonin	10/24/2019
PN 10401 Olympus BX50-51 Top Illuminator Installation Instructions	REV 7
SHEET 2 OF 4	

Nanodyne Replacement Illuminator for Olympus BX50 & BX51 Top Illuminator Installation Instructions: Step 1. Replace OEM Lamp with Nanodyne Illuminator.



Remove the lamp housing from the microscope. (Use the hex key tool stored in the top of the microscope to loosen it)

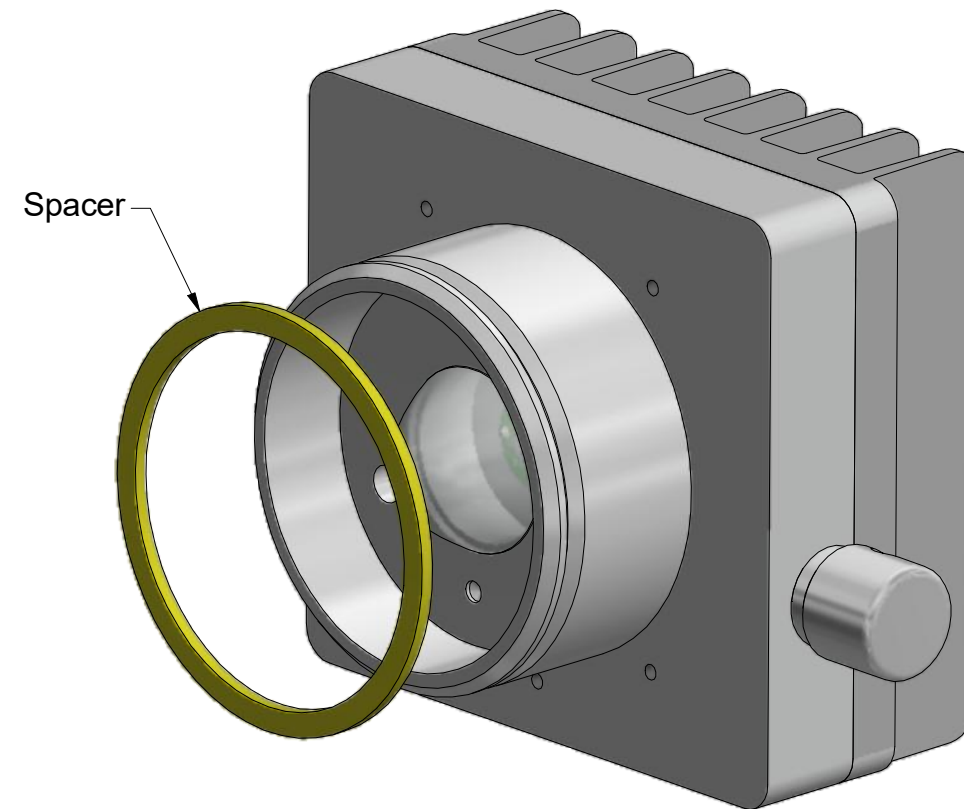

Attach the power cable to illuminator. There is not enough room to do that later.

Place the spacer in the microscope's illuminator port, then insert the illuminator. Tighten the set screw in the microscope while pressing the illuminator in as far as it goes.

See the next sheet for electrical safety information, and the installation is complete.

Wayne Bonin	10/24/2019
PN 10401 Olympus BX50-51 Top Illuminator Installation Instructions	REV 7
SHEET 3 OF 4	

Nanodyne Replacement Illuminator for Olympus BX50 & BX51 Top Illuminator Installation Instructions: Step 4. Electrical Safety.

BX50-51 Top Illuminator Replacement Safety Warnings, optional if you are not opening the back cover, but recommended.

If you also have a lower halogen illuminator that you are not replacing IGNORE THIS SECTION, as you still need the AC power for that illuminator.

The original 120/220VAC powered illuminator circuitry is completely obsolete by the Nanodyne equipment which is powered by a universal input wall plug power supply with low voltage DC output.

We recommend completely removing the original power supply circuitry to eliminate any possibility of an electrical or fire hazard in case someone mistakenly connects AC power to the microscope in the future.

AT THE VERY LEAST, remove the power leads (red arrows in photo 4a) from the AC input connector. They should be cut short so there is no possibility they could contact the power inlet, or insulated with heat shrink tubing or electrical tape.



(Optional) Installation of PN 10736 rubber plug is shown above.

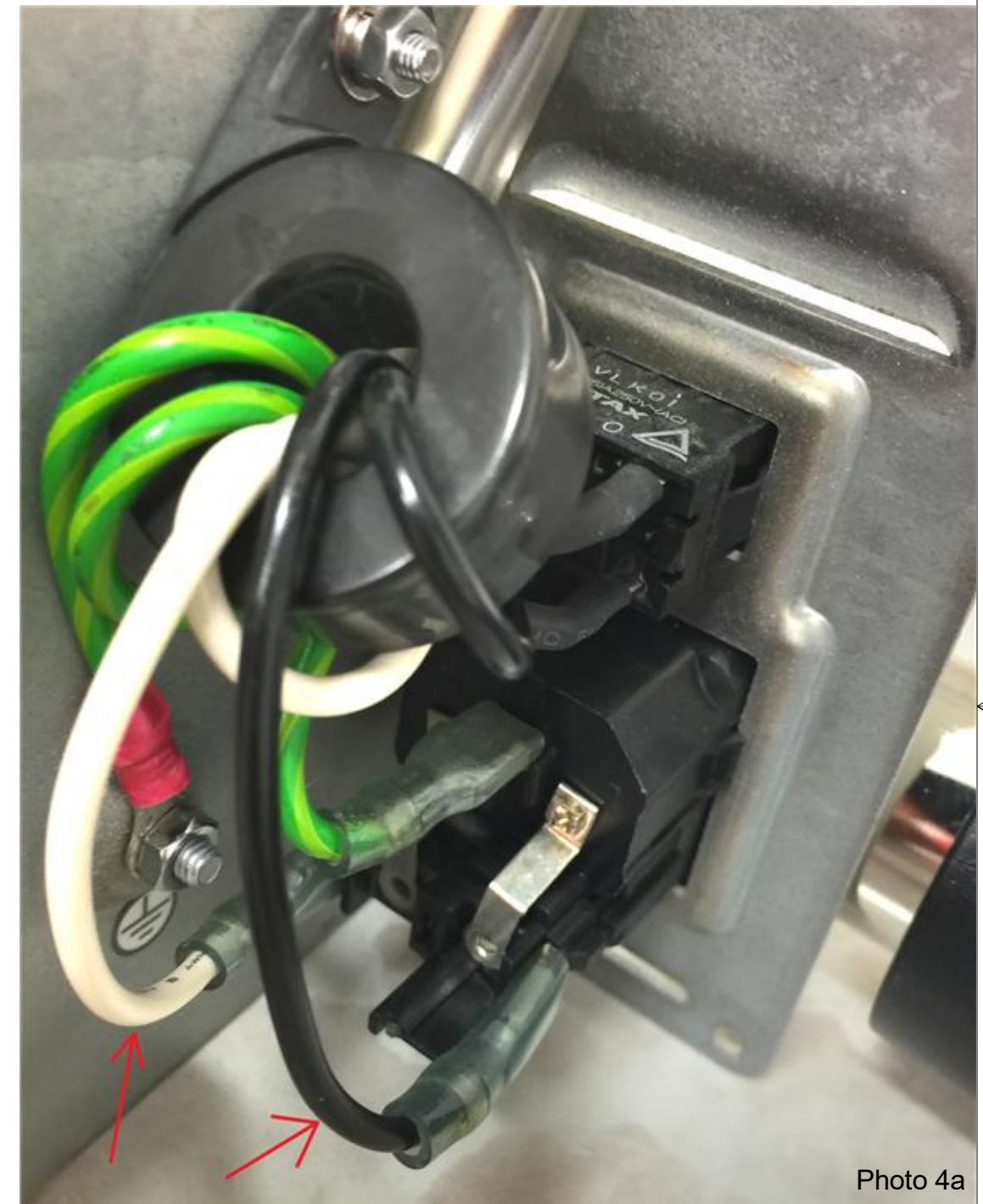

Inside view of BX50 obsolete AC power input.

Wayne Bonin	10/24/2019
PN 10401 Olympus BX50-51 Top Illuminator Installation Instructions	REV 7
SHEET 4 OF 4	